

B1-L2A2D

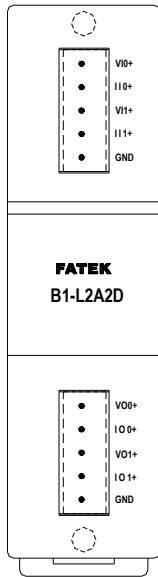

Pin Position	Explanation
VI0+	Channel 0 Analog Voltage Input
II0+	Channel 0 Analog Current Input
VI1+	Channel 1 Analog Voltage Input
II1+	Channel 1 Analog Current Input
GND	Ground Wire
VO0+	Channel 0 Analog Voltage Output
IO0+	Channel 0 Analog Current Output
VO1+	Channel 1 Analog Voltage Output
IO1+	Channel 1 Analog Current Output
GND	Ground Wire

B1-L2A2D Analog I/O Circuit Diagram

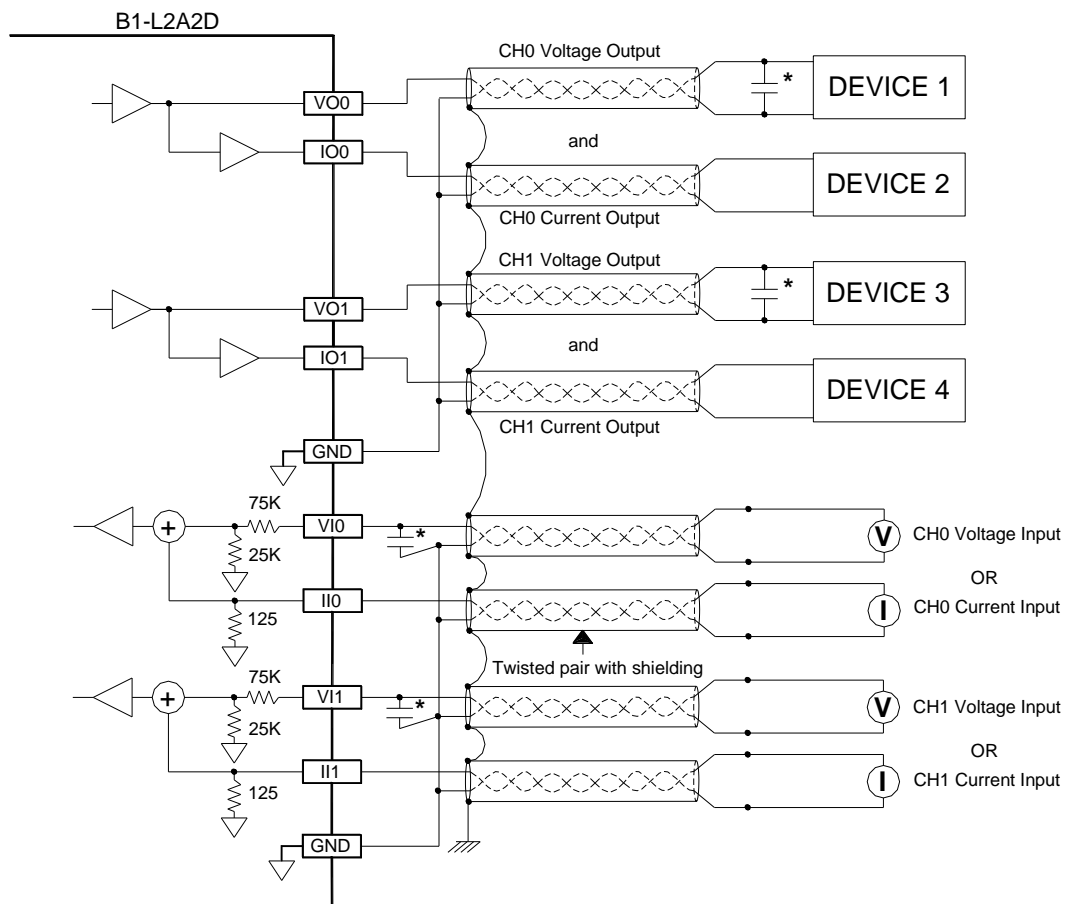

*0.1~0.47uF capacitor (to filter noise).....Advice to install, but not necessary!!

B1 Analog Expansion Board I/O Characteristics

The analog I/O conversion characteristics of these settings are illustrated below. Users can adjust different I/O forms by coordinating the conversion curve with various V/I (Voltage/Current) I/O settings.

Figure 1 : Analog Input Characteristics Curve

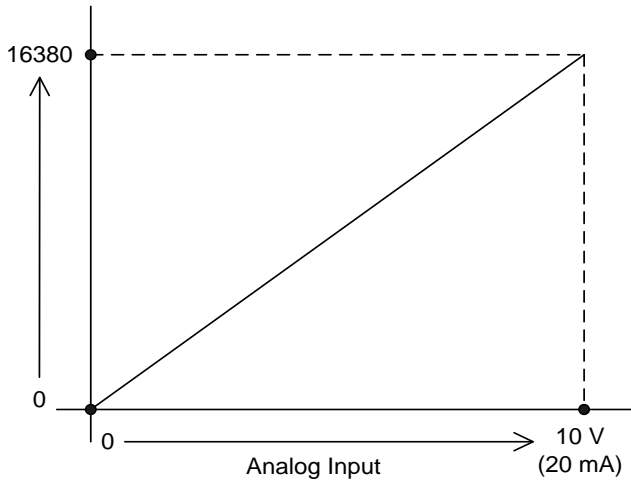

Figure 2 : Analog Output Characteristics Curve

